

Impact of Studying in the UK Booklet 2017-2018 Indonesia

Information and Advertising Booking Form
22 May 2017

Introduction

We are pleased to inform you that British Council Indonesia will be producing Impact of Studying in the UK Booklet for 2017/18



In addition to provide parents & students with facts and reasons on the excellence of UK education compare to other countries, our booklet also serves to help institutions:

- Promote and provide details on study programmes of each UK institutions, so that potential students can contact the institutions directly according to their interests.

The contents of the Impact of Studying in the UK Booklet are as follows:

- Study in the UK
- UK Education System
- Why Study in the UK
- Benefits of a UK Education
- Scholarships - Chevening
- Visa Services - Student Visa
- Alumni Testimonies

Target Audience & Circulation

The initial print of the booklet will be 4000 copies. The target audience of this booklet includes government officials, universities boards, students (high school, undergraduate, Masters, and Phd), school counsellors, parents and educationists.

The booklet will be distributed through the following channels:

- Direct distribution to Education Agents and Schools.
- British Council's education events.
- External (local institutions) events where British Council participates

Cost and Size of Space

Single page 20x20 cm: **GBP 850 (Net)**

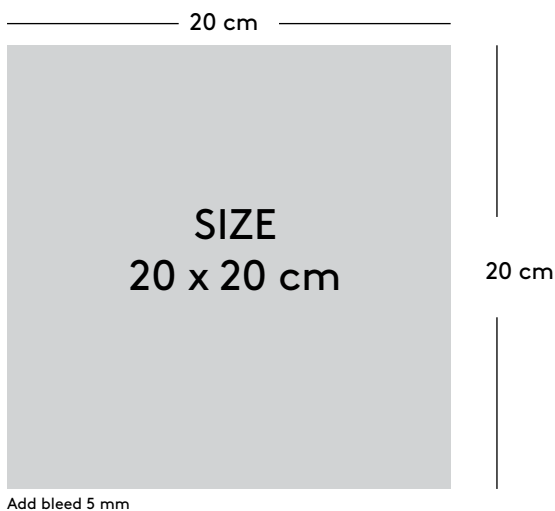

Advertorial design/ content can be provided by your institutions, if you need us to do the design please refer to the content requirement below:

- High quality images (min. resolution 300 dpi)
- Vector logo (Adobe PDF, Adobe Illustrator Format, EPS Format)
- Headings, sub-headings and body text

Ready to print file

- Size 20x20 cm, bleed 5mm
- Minimum resolution 300 dpi
- File can be in high resolution JPG, editable PDF, Adobe Illustrator file.

Advertorial will be placed based on Alphabetical name

Please fill in the form and return the form by email to lisa.wilianto@britishcouncil.or.id or the latest on **30 June 2017**

Contact Person

Lisa Wilianto

Programme Manager

Email: lisa.wilianto@britishcouncil.or.id

Mobile phone: +62 811 8177 539

Advertorial Booking Form

Name of Institution*

(this format will be used in all publicity)

Main Contact

Area code and Phone Number

Telephone

Email

Contact Address